

Product data sheet

Characteristics

XVS10MMW

Harmony XVS, N/A

Product availability: Non-Stock - Not normally stocked in distribution facility

Price*: 150.00 USD



Main

| | |
|---------------------------|--|
| Range of Product | Harmony XVS |
| Product or Component Type | Siren |
| Device short name | XVS |
| Color | White |
| Signalling type | 2 tones siren |
| [Us] rated supply voltage | 230 V AC |
| Noise level | 106 DB continuous or intermittent tone)1 m |

Complementary

| | |
|--|-------------------------------------|
| Material | PC body |
| Net Weight | 2.20 Lb(US) (1 kg) |
| Marking | CE |
| [Uimp] rated impulse withstand voltage | 4 KV |
| Current consumption | 40 mA 230 V |
| Clamping Connection Capacity | <= 1 x 1.5 mm ² |
| Electrical connection | Cable 0.26...0.33 in (6.5...8.5 mm) |
| Maximum Width | 4.49 In (114 mm) |
| Maximum Height | 4.49 In (114 mm) |
| Maximum Depth | 6.03 In (153.2 mm) |

Environment

| | |
|---------------------------------------|------------------------------------|
| Standards | EN/IEC 60947-1 EN/IEC 60947-5-1 |
| Protective treatment | TC |
| Ambient Air Temperature for Storage | -31...158 °F (-35...70 °C) |
| Ambient Air Temperature for Operation | -22...122 °F (-30...50 °C) |
| Electrical shock protection class | Class II EN/IEC 61140 |
| IP degree of protection | IP53 |

Ordering and shipping details

| | |
|-----------------------|--------------------------|
| Category | 22617 - XVC TOWER LIGHTS |
| Discount Schedule | XV |
| GTIN | 03389119045360 |
| Nbr. of units in pkg. | 1 |
| Package weight(Lbs) | 2.7 Lb(US) (1.22 kg) |
| Returnability | No |
| Country of origin | ID |

Packing Units

| | |
|------------------------------|--------------------------|
| Unit Type of Package 1 | PCE |
| Package 1 Height | 5.51 In (14 cm) |
| Package 1 width | 5.51 In (14 cm) |
| Package 1 Length | 7.68 In (19.5 cm) |
| Unit Type of Package 2 | S04 |
| Number of Units in Package 2 | 8 |
| Package 2 Weight | 24.78 Lb(US) (11.24 kg) |
| Package 2 Height | 11.81 In (30 cm) |
| Package 2 width | 15.75 In (40 cm) |
| Package 2 Length | 23.62 In (60 cm) |
| Unit Type of Package 3 | P06 |
| Number of Units in Package 3 | 32 |
| Package 3 Weight | 118.96 Lb(US) (53.96 kg) |
| Package 3 Height | 30.31 In (77 cm) |
| Package 3 width | 31.50 In (80 cm) |
| Package 3 Length | 23.62 In (60 cm) |

Offer Sustainability

| | |
|----------------------------|---|
| California proposition 65 | WARNING: This product can expose you to chemicals including: Lead and lead compounds, which is known to the State of California to cause cancer and birth defects or other reproductive harm. For more information go to www.P65Warnings.ca.gov |
| EU RoHS Directive | Pro-active compliance (Product out of EU RoHS legal scope) EU RoHS Declaration |
| Mercury free | Yes |
| RoHS exemption information | Yes |
| China RoHS Regulation | China RoHS Declaration |
| Environmental Disclosure | Product Environmental Profile |
| Circularity Profile | End Of Life Information |

Contractual warranty

| | |
|----------|-----------|
| Warranty | 18 months |
|----------|-----------|

Siren

Dimensions

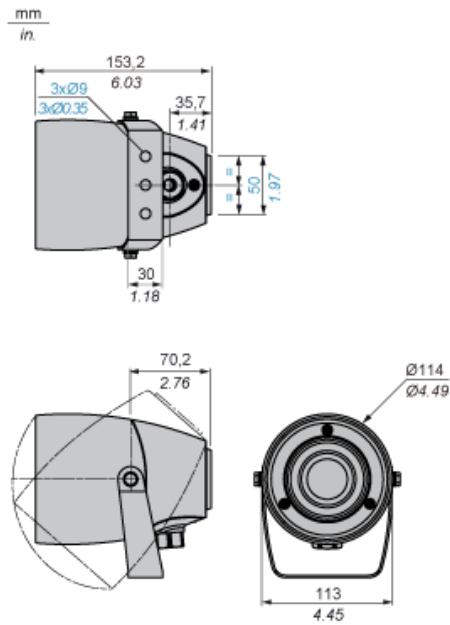

Product Life Status : Commercialised